

“Shut The Front Door!”: Obviating the Challenge of Large-Scale Extra Dimensions

RICHARD L. AMOROSO

*Noetic Advanced Studies Institute, Escalante Desert, UT 84714-5104 USA
amoroso@noeticadvancedstudies.us, www.noeticadvancedstudies.us*

Physics has been slowly and reluctantly beginning to address the role and fundamental basis of the ‘observer’ which has until now also been considered metaphysical and beyond the mandate empirical rigor. It is suggested that the fundamental premise of the currently dominant view of ‘Cognitive Theory’ - “Mind Equals Brain” is erroneous; and the associated belief that the ‘Planck scale, ‘the so-called basement level of reality’, as an appropriate arena from which to model psycho-physical bridging is also in error. In this paper we delineate a simple, inexpensive experimental design to ‘crack the so-called cosmic egg’ thereby opening the door to large-scale extra dimensions (LSXD) tantamount to the regime of the unified field and thus awareness. The methodology surmounts the quantum uncertainty principle in a manner violating Quantum Electrodynamics, (QED), a cornerstone of modern theoretical physics, by spectrographic analysis of newly theorized Tight-Bound State (TBS) Bohr orbits in ‘continuous-state’ transition frequencies of atomic hydrogen. If one wonders why QED violation in the spectra of atomic hydrogen relates to solving the mind-body (observer) problem; consider this a 1st wrench in a forthcoming tool box of Unified Field Mechanics, U_F that will soon enough in retrospect cause the current tools of Classical and Quantum Mechanics to appear as stone axes. Max Planck is credited as the founder of quantum mechanics with his 1900 quantum hypothesis that energy is radiated and absorbed discretely by the formulation, $E = \hbar \nu$. Empirically implementing this next paradigm shift utilizing parameters of the long sought associated ‘new physics’ of the 3rd regime (classical-quantum-unified) allows access to LSXD of space; thus pragmatically opening the domain of mental action for the 1st time in history. This rendering constitutes a massive paradigm shift creating a challenge for both the writer and the reader!

Keywords: Bohr orbit, Psycho-physical bridging, QED, Quantum theory, Spectroscopy, Tight-bound states, Uncertainty principle.

1. Introduction - Threshold of a 3rd Regime

“Shut The Front Door!”, a slang interjection or statement representing a moment of disbelief in US vernacular [1], is an appropriate ‘reverse psychological’ insult for this paper’s experimental challenge to the myopic presumptions of both Cognitive Neuroscience and contemporary physics that has thwarted progress in solving the mind-body problem (nature of the observer) like the most honored Mullah Nasrudin who losing his keys in his backyard looked for them instead at night under the street light in front of his house because it was easier to look there with his neighbors helping.

Quantum Electrodynamics (QED) sacrosanct for the past 50 years is now summarily being violated [2-4]. QED, the relativistic quantum field theory (RQFT) of electrodynamics describes the interaction of light and matter; and was the first theory to mesh full agreement between quantum mechanics and special relativity. Feynman, a QED founder called it “the jewel of physics” for its extreme accuracy in predictions such as the anomalous magnetic moment of the electron, and the Lamb shift in energy levels of hydrogen.

It is interesting that new TBS energy levels of hydrogen will now lead to QED being violated. Rowlands in terms of current thinking in contemporary physics hints at the dilemma that we satchet past here:

Physics at the fundamental level can be effectively reduced to an explanation of the structures and interactions of fermions. Fermions appear to be singularities rather than extended objects, but there is no obvious way of creating such structures within the 3-dimensional space of observation. However, the algebra associated with the Dirac equation appears to suggest that the fermion requires a double, rather than a single, vector space, and this would seem to be confirmed by the double rotation required by spin $\frac{1}{2}$ objects, and the

associated effects of *zitterbewegung* and Berry phase shift. Further investigation of the second ‘space’ reveals that it is, in effect, an ‘antispaces’, which contains the same information as real space but in a less accessible form. The two spaces effectively cancel to produce a norm 0 (nilpotent) object which has exactly the mathematical structure required to be a fermionic singularity [5].

Although the mathematics of Rowlands *avant-garde* nilpotent physics works brilliantly in extending our understanding of the nature of a fermionic singularity (as yet an open question in physics), for Noetic Field Theory (NFT): The quantization of Mind, for which Rowland’s model has recently even become a basis for solidifying NFT’s foundation [6,7]; elegant math is not necessarily tantamount to physics. The nature of the so-called fermionic singularity is profoundly unique in NFT; and even though the protocol introduced here would not work without that noetic nature being physically realistic, its technical description is beyond the scope of this paper [8-10] within which we outline the experiment and only delineate a minimum of associated parameters to help explain its radical theoretical foundations.

2. Physics New and Old - Protocol Philosophy

A wrinkle in atomic spectra may not initially appear as an appropriate crack in the ‘cosmic egg’ - meaning a door to empirically demonstrating the 1st indicia of the existence of Cartesian Interactive Dualism. To clarify, NFT [7-13] now has sufficiently firm theoretical grounds to declare that the Planck scale is ‘not the basement of reality’, albeit it is an oasis between the 1st and 3rd regimes of reality - a nilpotent boundary of the infinite potentia [5-7] hidden behind it or domain wall forming the virtual reality perceived by the Euclidean/ Minkowski observer. Just as the quantum regime was until recently invisible to the empirical tools of Newtonian or Classical Mechanics, so until now Unified Field Mechanics, U_F has remained invisible to the tools of quantum mechanics primarily because of the barrier associated with the uncertainty principle.

The uncertainty principle has been empirically demonstrated by the Stern-Gerlach experiment [14] where a continuous non-uniform em-field arbitrarily projected along the z-axis produces ‘space-quantization’ and by definition the quantum uncertainty principle under the auspices of the Copenhagen Interpretation of Quantum Theory. The simple solution to surmount uncertainty is to ‘do something else’ [6,8,15] which will only be given brief conceptual delineation here. The experiment to be presented revolves around an as yet obscure work by Vigier called ‘tight bound states’ (TBS) in the hydrogen atom [9,17]. Hydrogen is chosen for the experiment because of its atomic simplicity; it is surmised that a more complex atom might have a tendency to mask the anticipated effect making the putative result more difficult to observe.

The experiment if successful would demonstrate a violation of QED. The timing for theoretical acceptance is good because QED has recently been violated in Titanium atoms to a discernible degree [3]. Such preliminary experiments in the history of physics often start as tiny cracks in a theory that have to be repeated and extended many times to produce sufficiently salient effects. The TBS experiment introduced below promises to ‘Open the Front Door’ wide because it leaps beyond the standard model on a faster track by utilizing aspects of U_F mechanics; i.e. the several new QED violation experiments are standard 4D quantum mechanical and therefore unable to access the ‘hidden’ large-scale extra dimensional (LSXD) U_F regime.

History has incessantly demonstrated that it is human nature to resist new ideas. Thus it would be easier if one could merely describe the mechanical details of the TBS experiment without delving into a description of the theory behind it because it is currently extremely radical and such a perambulation most certainly will initially also appear sufficiently metaphysical (especially since it purports discovery of Cartesian dualism) to current thinking in mainstream physics to mow down the delicate bloom of open-minded consideration...

The spectra of hydrogen and associated Zeeman and Stark effects have been rigorously investigated over the last 100 years. What we propose requires no repeat or manipulation of that data which is used only as a comparative benchmark with the new TBS experimental data. We propose three new lines in the atomic transition frequency of hydrogen inconsistent with QED standards suggesting the existence of new TBS below the lowest traditional Bohr orbit (heretofore hidden behind the uncertainty principle) caused by a cyclical or holophote-like periodicity of LSXD resonant transitions. Imagine for the sake of simplistic illustration that the 1st Bohr orbit, s (without descriptive units) has a spectral energy volume of 10 and the 2nd Bohr orbit, p a volume of 20 units. Before we get more deeply into the TBS scenario let’s further explain the 10-20 energy volume metaphor. Imagine being in a symmetrically organized orchard, auditorium or grave yard where an observer will notice alternating paths extending to infinity or local barriers blocking the view in the near field. Coincidentally this appears like the interference fringes of a Moiré pattern. In HAM cosmologies Calabi-Yau-Dodecahedral-AdS₅-DS₅ 12D symmetry the ‘mirror image of the mirror image’ (conformal scale-invariant copies) of the 3D ‘particle in a box’ is causally

free of the 4D nilpotent Minkowski space resultant. 12D appears to be the minimal dimensionality for this condition to occur. This inherent structure allows us to set up the required rf-pulsed resonance hierarchy.

Figure 13e shows the possibility of three spectrographic results - spectral energy volumes of 12, 14 or 16 depending on whether the standing-wave structure of the resonance hierarchy cycle is fully parameterized or not. Thus if successful the TBS protocol will be distinct from the usual 10-20 QED spectrum of the hydrogen atom. This result would not only violate QED but also demonstrate the existence of LSXD which for our purposes opens the door to a regime of new physics able to cross the psycho-physical bridge leading to the 1st pragmatic model of 1st person 3rd person entanglement [8,11].

Under the auspices of the Copenhagen Interpretation protons are said to be created near the time of the Big Bang and their half-life has been confirmed to this order of temporal magnitude [18,19]. But this condition is independent of what one might say about de Broglie matter-waves applied to the de Broglie-Bohm Causal Stochastic Interpretation of quantum theory [20,21] well known to include a quantum potential or pilot wave that NFT additionally interprets to suggest that fermions embedded in spacetime are cyclically annihilated and recreated as an inherent ontological basis for the generation of observed reality (Figs. 2 and 3); which NFT further postulates in terms of Cramer's Transactional Interpretation (TI) [22], acts like a hyperspherical standing-wave of the future-past (Fig. 1). Cramer derived this basis for his interpretation by correspondence to the Wheeler-Feynman radiation law [23]. NFT takes this scenario a significant additional step by elevating both Cramer's TI and wave-particle duality to Principles of Cosmology. One gets from this concatenation an application of the Dirac equation where the annihilation-creation vectors applied to matter embedded in spacetime act as a locus of resultant LCU points able to not only model the arrow of time with large-scale continuous-state extra dimensions (LSXD); but also a description of the exciplex gating mechanism mediating the U_F . (See Figs. 2, 3 & 10)

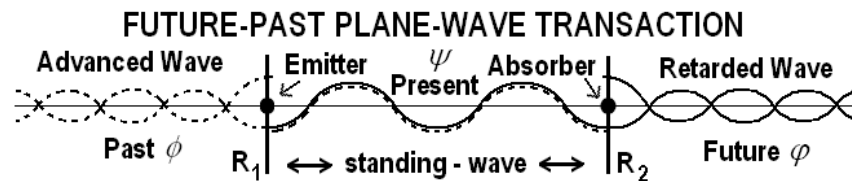

Figure 1. Conceptualized structure of a transaction (present quantum state or TI event) where the present (simplicistically) is a standing-wave of future-past elements [22]. A point is not a rigid singularity as in the classical sense, but has a complex structure like a mini-wormhole where R_1 & R_2 (like the frets holding the wire of a stringed instrument) represent opposite ends of its vibrational diameter. However a NFT HAM singularity is only cyclically discrete as shown in the text below.

Putting all this together (more is left out for brevity here) one gets instead of an inflationary Doppler Big Bang universe, a 'continuous-state' anthropic multiverse [8] where the energy of inflation is internalized locally as a form of gravitational free-fall - giving the Euclidean observer his façade of virtual reality (Figs. 2 & 3). If this sounds like a horrendous concatenation violating Occam's razor, be reminded that if one is inclined to accept the need for a 'life principle' - even the founders of the current interpretation of quantum theory maintained that it was incapable of describing biological systems; and the ever so popular Big Bang cosmology is Darwinian and naturalistic - thus void of an anthropic principle. Therefore to this author's thinking there is little choice other than to follow the path presented here especially since additional degrees of freedom are required to go beyond the mechanistic fallacy of cognitive neuroscience.

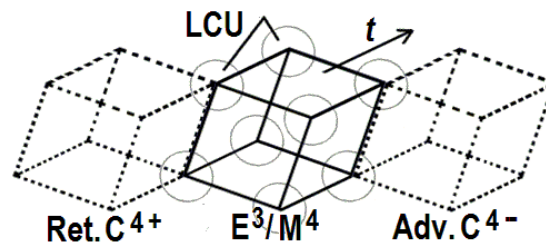

Figure 2. How observed (virtual) 3D reality (center) arises from the infinite potentia of 12D space (like a CI transaction). The 'standing-wave-like' (retarded-advanced future-past) mirror symmetric elements, C^{4+} / C^{4-} (where C^4 signifies an 8D potentia of complex continuous-state space is distinguished from the locally realized visible 3D spacetime) produce the observed Euclidian, E_3 , Minkowski, M_4 space (center) as a closed resultant. Least Cosmological Units (LCU) governing evolution of the 'points' of 3D reality are represented by circles. The Advanced-Retarded future-past cubes in HD space guide the evolution of the central cube (our virtual reality) that emerges from potentia elements of HD U_F space.

The Continuous-State property of the LCU space-spacetime raster forms the open-closed structure of its ‘singularity’. Leibnitz in an argument with Newton over whether spacetime was relational or absolute called this conundrum an antinomy - that space was an open-closed duality of the two. In HAM cosmology [8,11] the Hubble sphere, H_R is a self-organized complex system - closed and finite in time, but open and infinite in eternity which is a conformal scale-invariant property symbolic especially of the continuous-state LCU structure modulated by the coherence force of the U_F .

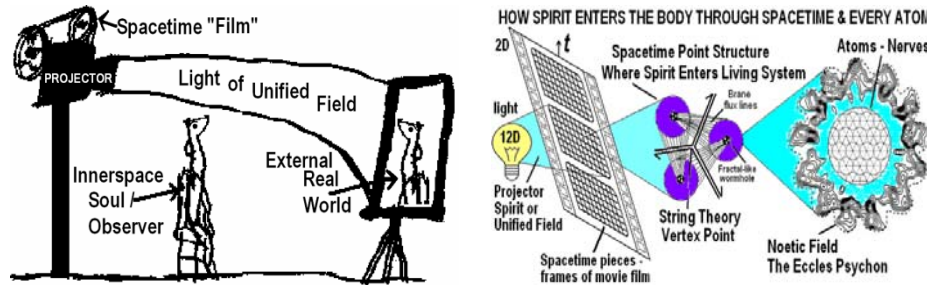

Figure 3. a) Macroscopic movie theatre model of virtual reality (like a hyperdimensional hologram) and the observer’s place in the theatre. b) Microscopic details of transduction of the U_F through the complex exciplex spacetime raster LCU gate (Fig. 10) into every point, atom and thus molecule of self-organized living systems (SOLS) the propagation of which also produces a locus of spacetime points associated with the arrow of time because it is part of the structure and content of the observers mind.

3. Devil in the Details - Continuous-State, LCUs and the Synchronization Backbone

One of the most amazing realizations during development of HAM cosmology was the inherent synchronization backbone associated with the nonlocal Continuous-State cycle. Even the author himself does not yet fully comprehend the structure of an LCU or its gating mechanism so additional profundity looms. The idea of a spacetime synchronization backbone arose with Feynman’s suggestion of its requirement in the development of quantum computers (QC) [8,24]. But researchers in the QC field gave up the idea as intractable not realizing that this was the case only in terms of the 4D Copenhagen Interpretation of quantum theory. In 12D it is miraculous and like getting half the QC for free! What researchers attempted could best be described as a form of ‘bi-locality’ not a breaking through uncertainty to the essential nonlocal LSXD criteria for a synchronization backbone. However Feynman’s comment was brief leaving that restriction unclear to Copenhagen regime philosophy and tools.

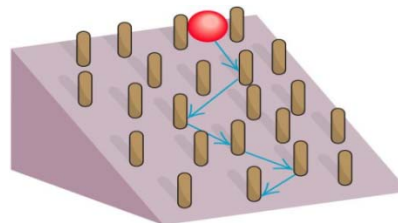

Figure 4. The Continuous-State process can be thought of as the path of a fermion (red ball) embedded in a spacetime raster (not as shown but instead embedded in a Riemann hypersphere) that is continuously rotating such that the fermion remains centralized as if in a form of gravitational free-fall.

The chaotic motion of a bouncing ball on a harmonically forced oscillator like the motion of a ball rolling down an inclined plane and bouncing off pegs in its path is analogous to the continuous-state process of the LCU raster of spacetime in the presence of the U_F . The synchronization backbone forms the geometric topology or domain wall of continuous-state Calabi-Yau mirror symmetry. There is a sort of mantra associated with its structural-phenomenology: A ‘Continuous-state spin exchange dimensional reduction compactification process’.

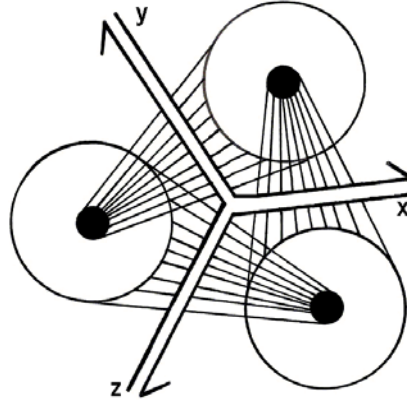

Figure 5. Triune structure of a conceptualized solitary LCU that like an isolated quark does not exist in nature. The central parallel lines are a Witten string vertex [32] with properties of a complex Riemann sphere able to continuously rotate from zero to infinity. The field lines represent the ‘super quantum potential’ of the unified field, U_F . This LCU structure is the NFT extension of the Rowland fermionic singularity [5].

As a portion of U_F dynamics the topology of the continuous-state process also includes gravitational elements called ‘parallel transport’ [8,31] which creates what physicists call a ‘deficit angle’. What this means is that a fermion following a geodesic path around the edge of a hypercube does not return to the precise fermionic vertex it originated from at the beginning of the cycle but incurs a deficit angle or gap between the original point and new final point. This gap in the Calabi-Yau mirror symmetric spin-exchange process is like a relay race baton passing where the electron for example ‘leapfrogs’ across the deficit angle gap (and recouples) in the standing wave structure of the Minkowski space resultant maintaining the properties of the uncertainty principle while in the nonlocal Calabi-Yau mirror symmetric background the continuous-state dimensional reduction compactification process runs smoothly through its 12D to 0D cycle - a stereographic property of a Riemann sphere rotation from zero to infinity.

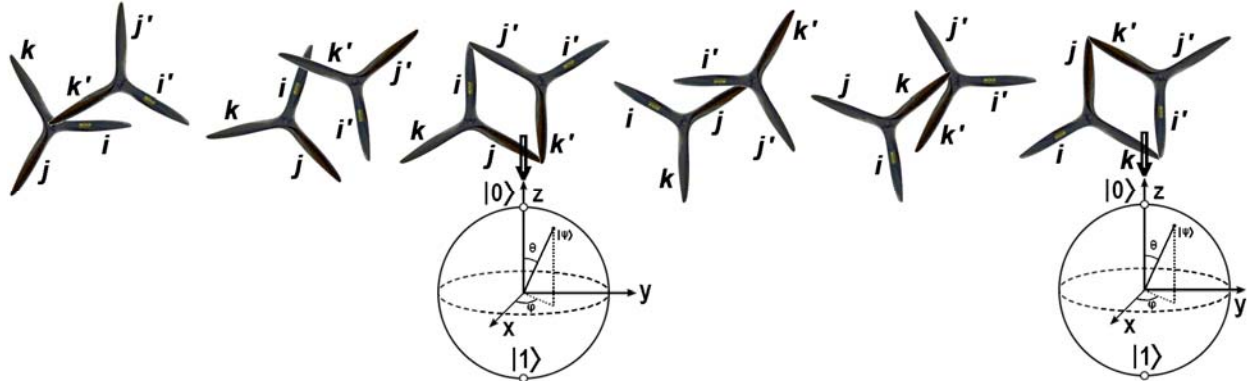

Figure 6. Segment of proximal HD Calabi-Yau mirror symmetric 3-folds represented as dual quaternion trefoils undergoing continuous-state rotation periodically coupling into a Euclidean 3-space resultant.

This horrendous concatenation occurs as the basis for the arrow of time because our temporal virtual reality surfs as it were of the face of the LSXD eternal realm hidden behind it. (The discrete frames of spacetime film in Fig. 3 producing the continuous virtual image of reality relativistically on the screen) These parameters are essential to the LCU as an exciplex gating mechanism - This is how each point (LCU open-closed singularity - like a rotating light house beacon) is created in the temporal locus and allows the U_F 's ‘force of coherence’ to modulate complex self-organized living systems (SOLS) [11] as the organizing principle itself and likewise mediate the physical basis of qualia [10-12]. We will do our best to clarify this scenario in the text and figures in sections following.

We are not yet finished outlining the required battery of new physical parameters; recall that NFT represents a whole paradigm shift. (why it hasn't been easy this past 1,000 years) WE MUST also utilize the parameters of another well established and generally ignored aspect of contemporary physics called Extended Electromagnetic Theory [25-27] in conjunction with a covariant Dirac polarized vacuum (ignored also) [28]; both because physicists erroneously believe they conflict with Gauge Theory which has been eminently successful for decades. Now we are finally be set up with enough parameters to putatively manipulate the spacetime backcloth (Einstein energy dependent spacetime metric) [29,30].

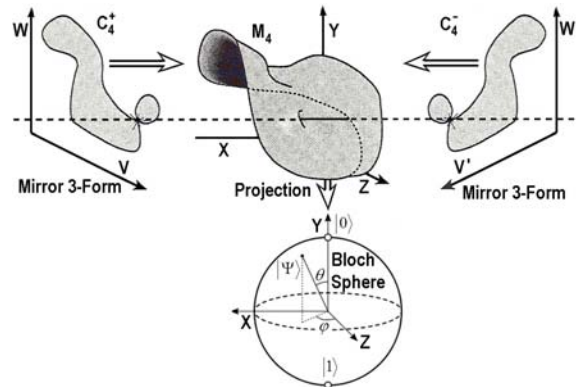

Figure 7. Complex Calabi-Yau mirror symmetric 3-form potentia, C_4 become an embedded quantum resultant in Minkowski space, M_4 . This resultant projection entails a continuous quantum state evolution represented as a Bloch 2-Sphere. Representing the lower portion that embeds in local spacetime; there is an additional 5D dodecahedral duality above this projection embedded in the infinite potentia of the U_F from which it arises.

Metaphorically if one throws a stone in water concentric ripples occur. If one throws two stones regions of destructive and constructive interference occur. We will utilize an M-Theoretic Calabi-Yau symmetric version of this model to set up an rf-pulsed spacetime resonance hierarchy to access the 'hidden' regime of the U_F [8]. In the next series of several figures (Figs. 5-8) we will attempt to clarify the continuous-state structure of LSXD as it applies to HAM cosmology.

The noeon mediating the U_F does not imply the usual phenomenological exchange of energy as in a standard field interaction such as the photon of the electromagnetic field; but constitutes an ontological exchange (without energy transfer). This is achieved by a process called 'topological switching' and implies instead a 'force of coherence' inherent in the action of the U_F . This process also allows the quantum uncertainty principle defined by the Copenhagen Interpretation of quantum theory to be surmounted [8]. Figure 8 illustrates a nilpotent continuous-state regime cycling from a 12D dodecahedral de Sitter space [38] through an intermediate Calabi-Yau mirror symmetry to a virtual 'standing-wave' nilpotent 3D Euclidean space resultant.

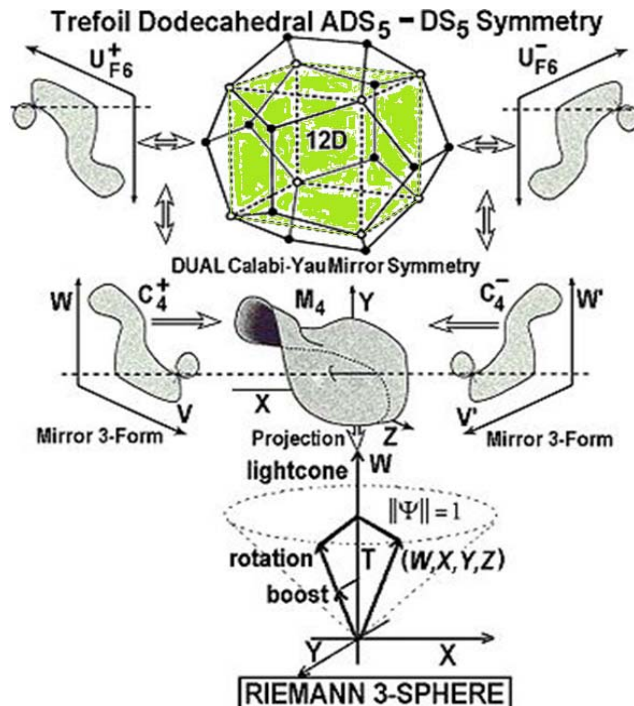

Figure 8. Complete LSXD regime of HAM cosmology illustrating the hierarchy of its geometric topology. Dodecahedral involute properties, as well as the continuous-state exciplex 'hysteresis loop' of noeon injection not shown. It represents a unique M-Theoretic model of 'Continuous-State' U_F dynamics as it relates to NFT and its putative exchange quanta of the U_F called the noeon.

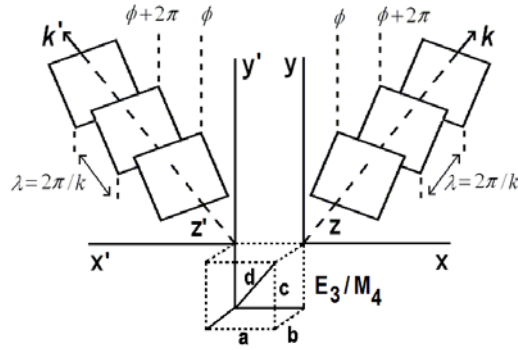

Figure 9. Calabi-Yau future-past mirror symmetry potentia illustrated as tiered surfaces (additional dimensionality suppressed) of constant phase, in this case to represent cyclic components of evenly spaced orthogonal standing reality waves with the E_3/M_4 cubic resultant localized at the bottom. The resultant locked in 4D by the uncertainty principle.

We extend Vigier's original model of TBS in hydrogen [17] to include a unique 12D M-Theoretic perspective [8] with a Calabi-Yau : Dodecahedral involute mirror symmetry [6] in Continuous-State HD space [8,11] elevating Cramer's Transactional model [22] and wave-particle duality to principles of cosmology. The 4-Space nilpotent resultant of the E_3/M_4 virtual present which is a standing-wave of the future-past is shown in Figs. 2-9. M_4 being 'locked' into place cyclically by the uncertainty principle [8].

The HD or XD are not curled up at the Planck scale because they are invisible; but they are Large-scale XD (LSXD) [8] because of subtractive interferometry as it were of the $C_4^+ - M_4 - C_4^-$ standing-wave modes [8] that operates like a movie theatre where discrete frames of film moving through the projector at a few cm/sec appear continuous on the screen. For our virtual reality - Exchange quanta of the U_F is relativistically 'pumped' through discrete holographic-like LCU tiling the raster of spacetime producing the virtual image of the Minkowski space present. So behind the virtual veil is a continuous-state cycle from $0 \Leftrightarrow \infty$ as shown in Fig. 3.

4. More Experimental Theory

The Born-Oppenheimer (BO) approximation [33] which is based on the fact that within molecular systems fast-moving electrons can be distinguished from slow-moving nuclei allows the wavefunction of a molecule to be broken into its electronic and nuclear (vibrational, rotational) $\Psi_{\text{Total}} = \psi_{\text{Electronic}} \times \psi_{\text{Nuclear}}$ components for easier calculation. The assumption is made that if nonadiabatic coupling terms are negligibly small then the upper electronic surfaces have no effect on the nuclear wave function of the lower surface. This assumption is not considered dependent on the systems energy. However, the ordinary BO approximation was also employed for cases where these coupling terms are not necessarily small, assuming that the energy can be made as low as required. The justification for applying the approximation in such a case is that for a low enough energy the upper adiabatic surfaces are classically forbidden, implying that the components of the total wave function related to these states are negligibly small. As a result the terms that contain the product of these components with the nonadiabatic coupling terms are also small, and will have a minor effect on the dynamical process.

The protocol tests for both the existence of TBS and also for LSXD. HAM Cosmology predicts novel periodic HD cavities in the brane topology of Calabi-Yau : Dodecahedral AdS_5-DS_5 mirror symmetry. Simplistically a tunable NMR device acts on a vial of hydrogen over a range of de Broglie wavelengths set for specific Cavity-QED resonances to probe the lowest Bohr orbit for TBS conditions. If our cosmological model is correct there will be novel resonances that cannot correspond to either classical wave mechanics or Copenhagen QED modes. One might suspect C-QED to detect nodes in the Dirac spherical rotation of the electron (cyclical pattern of Klein bottle open-closed modes). Critics might say this is just a 4D Dirac effect of the putative Klein bottle symmetries in the electron's dual spinor rotation. But our LSXD cosmology predicts a much richer Calabi-Yau mirror symmetry within the higher 9D brane topology so there "should" be a cycle of novel TBS resonances in the Calabi-Yau symmetry. Likewise these resonance nodes would have de Broglie wavelengths different than any higher Bohr orbit excitation in Hydrogen. It may be possible to predict the de Broglie wavelengths in the resonance hierarchy if the topology can be theoretically determined or if a clear C-QED resonance hierarchy appears, the topological structure

of higher dimensions may be revealed. Vigier discussed using deuterium; it is an open question if that would make a qualitative difference in success or results in such an experiment. It will be easy enough to test both cases.

EXCIPLEX PROPERTIES OF SPACETIME AND MATTER

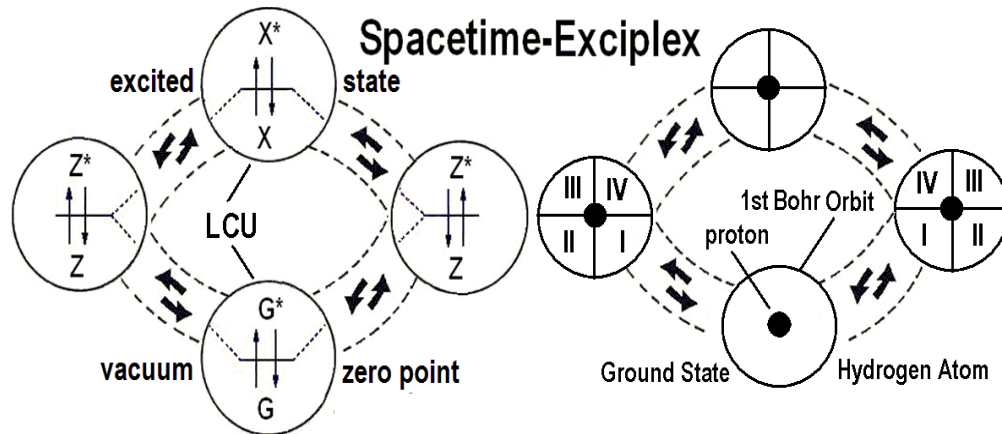

Figure 10. a) Least cosmological unit (LCU) exciplex complex tiling the spacetime backcloth of HAM cosmology. The array of LCUs acts as a gating mechanism for entry of the U_F into every point in Minkowski 4-space and all matter [8]. b) Conformal scale-invariant properties related to TBS in the hydrogen atom as it pertains to LSXD and the oscillating form of Planck’s constant fluctuating from the continuous-state asymptotic virtual Planck scale to the Larmor radius of the hydrogen atom [9,17].

Another way of looking at the experimental design set up is as a special case for manipulating the Lorentz Transformation [34,35] - Aspects of a spacetime exciplex model [8] in terms of restrictions imposed by Cramer’s Transactional Interpretation [22] on mirror symmetry can be used for the putative detection of virtual tachyon-tardyon interactions in *zitterbewegung* [5]. We have designed a tachyon measurement experiment [36] by initially considering Bohr’s starting point for the development of quantum theory, i.e. the emission of photons by atoms from quantum jumps between stable Bohr orbits. We do this from the point of view of the de Broglie-Bohm causal stochastic interpretation in order to take into consideration new laser experimental results described by Kowalski [34,35].

Re-quoting Rowlands from pg. 1: “Fermions appear to be singularities rather than extended objects...requires a double, rather than a single, vector space, and this would seem to be confirmed by the double rotation required by spin $\frac{1}{2}$ objects,” [5]. This represents the crux of the nut to be cracked. As we already stated Rowlands’ addition of an antispaces is a brilliant extension of how to understand the nature of a fermionic vertex especially as we feel it represents a clear conceptualization of the lock-down of HD potentia components of the local quantum state ‘resultant’ that produces the uncertainty principle. The absolute nature of the fermionic singularity requires the structure of the LCU.

This is conceptually illustrated in the usual 2D illustration of a 3D space immersion of a 4D Klein bottle. Dissecting a Klein bottle into halves along its plane of symmetry results in two mirror image Möbius strips, one that has left-handed half-twist symmetry and the other with a right-handed half-twist symmetry. The Klein bottle unlike the Möbius strip is a closed 2D manifold without boundary; but unlike the Möbius strip which can be embedded in 3D Euclidean space, the Klein bottle can only be embed in a 4D or higher dimensional space. By adding a fourth dimension to the 3D space, the self-intersection can be eliminated. This is the property we wish to extend beyond the Rowlands singularity.

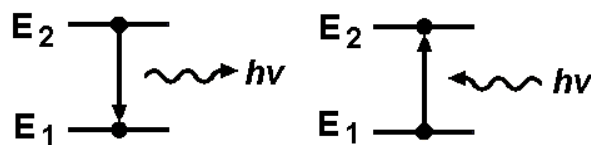

Figure 11. a) Decrease in energy level E_2 to E_1 resulting in photon emission (squiggly arrow) with quantized energy, $h\nu$. b) An increase in energy level from E_1 to E_2 resulting from absorption of a photon (squiggly arrow) also with energy, $h\nu$. This is the simplistic basis for spectrographic analysis of the quanta in a particular atomic orbit. The TBS experiment anticipates 3 new spectral lines in atomic hydrogen under the novel conditions set up by the apparatus.

Just like Classical Mechanics had no access beyond 3D Euclidean space, so Quantum Mechanics or the Standard Model has no access beyond 4D Einstein-Minkowski-Riemann space. Thus the U_F Mechanics of NFT introduces an additional complex 8D space - A 12D total comprised of nine spatial and three temporal; but because of the 4D Minkowski resultant being virtual and the involute properties of the topology operationally the HD space is 6D, with three temporal dimensions and three ‘energetic’ dimensional control factors of the U_F acting like a ‘super quantum potential’ [8,21]. When this 12D structure is put into the HAM Continuous-State cycle with properties like a Moiré pattern added to the periodicity of the LCU gating mechanism; we are finally set up to understand the topological geometry of TBS parameters.

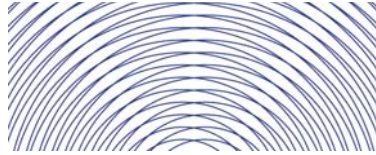

Figure 12. Periodic Moiré-like properties of the Continuous-state backcloth allow access to the LSXD regime by utilizing an rf-pulsed resonance hierarchy.

As one knows light emitted from atoms during transitions of electrons from higher to lower energy states takes the form of photon quanta carrying energy and angular momentum. Any causal description of such a process implies that one adds to the restoring force of the harmonic oscillator an additional radiation (decelerating) resistance associated (derived from) with the electromagnetic (force) field of the emitted photon by the action-equal-reaction law. Any new causal condition thus implies that one must add a new force to the Coulomb force acting at random and which we suggest is related to ZPF vacuum resonant coupling and motions of the polarized Dirac aether. In this respect we prefer an extension of the model proposed by Rowlands [5] as mentioned above. We assume that the wave and particle aspects of electrons and photons are built with real extended spacetime structures containing internal oscillations of point-like electromagnetic topological charges, e^\pm within an extended form of the causal stochastic interpretation of quantum mechanics.

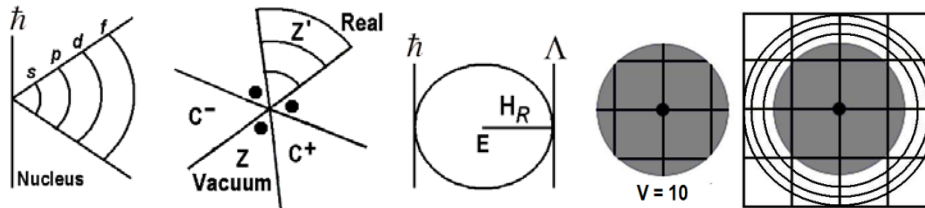

Figure 13. Historical evolution of atomic concepts. a) 2D representation of 3D reduction cone of standard Bohr orbits. b) Z' Real is same as (a), Z Vacuum is the Rowland’s nilpotent doubling, C^+ & C^- complex Calabi-Yau mirror symmetric generators & the 3 dots represent continuous-state control elements. c) Wave function domain of the Hubble Universe, $H = \Psi$ with a 1st and 2nd quantization, \hbar , Λ respectively of the Hubble radius, H_R with the Earth observer, E in center. d) Conceptualized area, $V=10$; see text. (central dot is proton) for the usual representation of the s Bohr orbital in a hydrogen atom. e) Same as (d) but with additional LSXD complex TBS space area represented. In reality the square would be folded up into a 3-torus or HD Klein bottle. The additional three concentric circles beyond the $V = 10$ volume of the gray circle representing the hydrogen atom s orbital are meant to represent the added TBS periodic LSXD 12-14-16 energy volume cycles of the continuous-state matter-wave annihilation-creation process.

Kowalski’s interpretation [34,35] drawn from recent laser experiments showing that emission and absorption between Bohr atomic states take place within a time interval equal to one period of the emitted-absorbed photon wave, the corresponding transition time is the time needed for the orbiting electron to travel one full orbit around the nucleus. Kowalski describes the additions to the usual theory of atomic structure. In the noetic theory the Kowalski additions, specifically the ‘Kowalski time interval’ are probably a key element in setting up the HD symmetry conditions of the TBS resonance hierarchy which can be further manipulated in terms of new parameters related to LSXD to test for U_F action and new cyclical continuous-state quantum cavity dynamics.

5. Experimental Design - Testing for and Manipulating TBS

Vigier et al. [17] has proposed TBS below the 1st Bohr orbit in the Hydrogen atom. Utilizing tenets of the original

hadronic form of string theory such as a variable string tension, T_S where the Planck constant, \hbar is replaced with a version of the original Stoney, $\tilde{\lambda}$ where \hbar is an asymptote never reached and instead oscillates from a virtual Planck asymptote to the Larmor radius of the hydrogen atom, i.e. the so-called Planck scale is a mathematical restriction (not physical) imposed by the limitations of the Copenhagen Interpretation and is not a fundamental physical barrier other than for Minkowski space [8]. LSXD exist behind it. Key to operation of the experiment is what we have termed a ‘couple-punch’ (Table 1). Utilizing relativistic quantum field theory (RQFT) at the moment of spin-spin coupling an rf-pulse is ‘kicked’ at various phases of a Bessel function coordinate harmonically set to coincide with putative phases in the Continuous-State cycle of TBS [8-10]. This protocol is considered simplest and least expensive of the 12 empirical tests so far derived by the author [10-13].

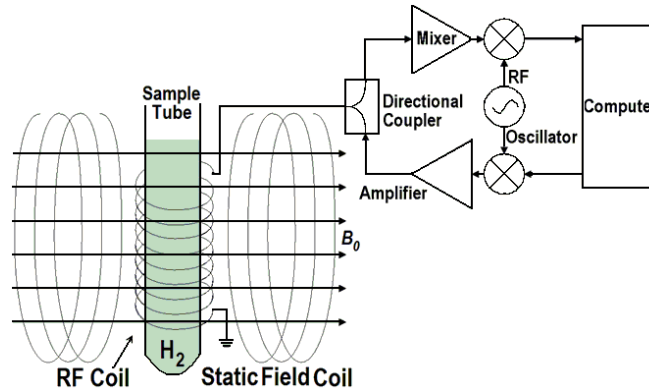

Figure 14. NMR apparatus designed to manipulate TBS in Hydrogen. The Fig. only shows possible details for rf-modulating TBS QED resonance, not the spectrographic recording and analysis components.

Some experimental evidence has been found to support this view showing the possibility that the interaction of these extended structures in space involve real physical vacuum couplings by resonance with the subquantum Dirac ether. Because of photon mass the CSI model, any causal description implies that for photons carrying energy and momentum one must add to the restoring force of the harmonic oscillator an additional radiation (decelerating) resistance derived from the EM (force) field of the emitted photon by the action-equal-reaction law. Kowalski has shown that emission and absorption between atomic states take place within a time interval equal to one period of the emitted or absorbed photon wave. The corresponding transition time corresponds to the time required to travel one full orbit around the nucleus. Individual photons are extended spacetime structures containing two opposite point-like charges rotating at a velocity near c , at the opposite sides of a rotating diameter with a mass, $m = 10^{-65}$ g and with an internal oscillation $E = m^2 = \hbar \nu$. Thus a new causal description implies the addition of a new component to the Coulomb force acting randomly and may be related to quantum fluctuations. We believe this new relationship has some significance for our model of vacuum C-QED blackbody absorption/emission equilibrium.

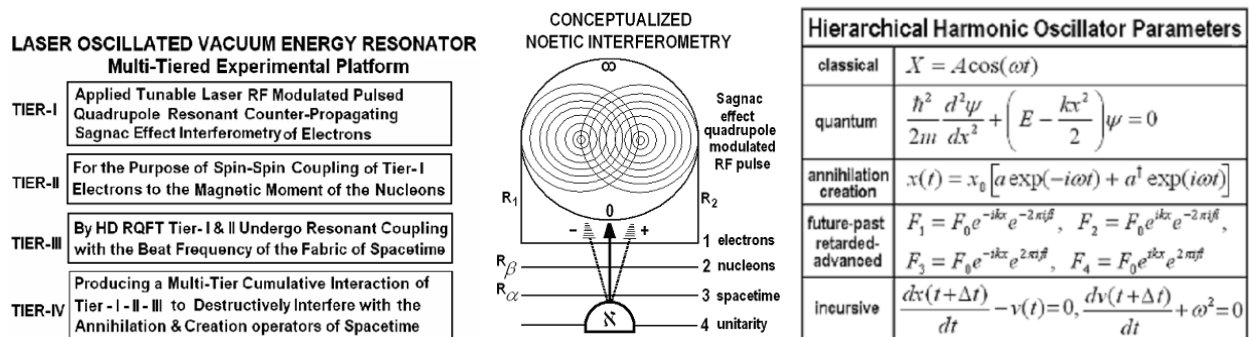

Figure 15. a) Top down list of the rf-resonance hierarchy for accessing HD space. b) The spheroid is a 2D representation of a HD complex Riemann sphere able to spin-flip HD brane coupling dynamics from zero to infinity and act as a holophote or ‘light house’ exciplex pumping mechanism to mediate the action of the U_F into spacetime. c) Basic conceptual mathematical components of the rf-pulsed applied harmonic oscillator resonance hierarchy in descending order: classical, quantum, relativistic, transactional and incursive are all required in order to achieve coherent control of the inherent conformal, scale-invariant properties of the HD Dirac polarized vacuum.

6. Experimental Procedure

If for the sake of illustration we arbitrarily assume the s orbital of a hydrogen atom has an energy volume of 10 and the p orbital an energy volume of 20. To discover TBS we will investigate the possibility of heretofore unknown volume possibilities arising from cyclical fluctuations in LSXD Calabi-Yau mirror symmetry dynamics. This is in addition to the Vigier TBS model.

As in the perspective of rows of seats in an auditorium, rows of trees in an orchard or rows of headstones in a cemetery, from certain positions the line of sight is either open to infinity or blocked. This is the assumption we make about the continuous-state cyclicity of HD space.

Then if the theory has a basis in physical reality and we are able to measure it, we propose that at certain nodes in the cycle we would discover cavity volumes of say 12, 14, and 16. We propose the possibility of three LSXD cavity modes like ‘phase locked loops’ depending on the cycle position - maximal, intermediate and minimal.

The mechanical engineering property of perfect rolling motion or perfect rolling contact is another metaphor for illustrating how the continuous-state cycle operates. A logarithmic spiral can be sliced into curved segments; and ellipsoids of various radii can be constructed from the curved segments. If the spheroids are made to touch and roll without slippage during some rotational cycles the points of contact will return to the original position, i.e. forming a pattern of open and closed moments like orchard rows.

TABLE I

<u>KICK</u>	<u>PULL</u>	<u>$P + K$</u>	<u>$K + P$</u>
R	R	$R + A$	$R + A$
A	A	$A + R$	$A + R$
$R + A$	$R + A$	$A = R$	
$A + R$	$A + R$		
$A = R$	$A = R$		

Table I. Possible TBS experimental Kick-Pull (K - P) coupling mode parameters. R signifies a retarded K or K coupling, A respectively of advanced K coupling. The plus (+) sign signifies sequential order and the equals sign (=) means simultaneous action for a total of 15 experimental KP coupling options. Table 1 shows 15 ways to test Calab-Yau symmetric - CQED TBS parameters and LSXD.

7. Conclusion

Utilizing a postulates of the recently formulated paradigm shift in cosmology called the Holographic Anthropic Multiverse [8,11] that employs extensions of quantum theory, gravitation and electromagnetism, one is able to design experiments that putatively open the door to the 3rd regime of reality (classical-quantum-unified). If the model proves correct it will be the beginning of empirical access to tenets of unified field mechanics opening the door to a battery of new technologies including bulk universal quantum computing [8].

The key aspect is the cyclical nature of the continuous-state hypothesis that provides a simple method for surmounting quantum uncertainty, suggested to be a limiting factor of the Copenhagen Interpretation of quantum theory; ‘behind’ which the door opens to large-scale extra dimensions wherein lies the regime of action of the unified field and the teleology of mind-body interaction.

We have proposed a simple inexpensive experiment that suggests three new spectral lines in the hydrogen atom. The protocol operates by utility of a simple rf-pulsed resonance hierarchy timed to coincide with specific parameters of the continuous-state process when periodic openings occur into the higher dimensional regime.

References

- [1] The slang phrase ‘Shut the Front Door’ was originally coined by Buckethead on 101.1 WJRR Radio, Orlando, FL, USA, www.wjrr.com.
- [2] Chantler, C.T. et al. (2012) Testing three-body quantum electrodynamics with trapped Ti^{20+} ions: Evidence for a Z-dependent divergence between experiment and calculation, PRL 109, 153001.
- [3] Chantler, C. T. (2004). Discrepancies in quantum electro-dynamics, Radiation Physics and Chemistry, 71(3), 611-617.
- [4] Pohl, R., Antognini, A., Nez, F. et al. (2010) The size of the proton, Nature (London) 466; 7303: 213-216.
- [5] Rowlands, P. (2013) Space and Antispace, in RL Amoroso, LH Kauffman & P. Rowlands (eds.), The Physics of Reality:

Space, Time, Matter, Cosmos, Singapore: World Scientific Publishers.

- [6] Amoroso, R. L. & Kauffman, L. H. (2013) The relativistic qubit, in Amoroso, R. L., Kauffman, L. H. & Rowlands, P. (eds.) *The Physics of Reality: Space, Time, Matter, Cosmos*, Singapore: World Scientific Publishers.
- [7] Amoroso, R. L. & Kauffman, L. H. & Rowlands, P. (2013) Exploring Novel Cyclical Extensions of Hamilton's Dual-Quaternion Algebra, in Amoroso, R. L., Kauffman, L. H. & Rowlands, P. (eds.) *The Physics of Reality: Space, Time, Matter, Cosmos*, Singapore: World Scientific Publishers.
- [8] Amoroso, R. L., & Rauscher, E. A. (2009) *The Holographic Anthropic Multiverse: Formalizing the Geometry of Ultimate Reality*, Singapore: World Scientific.
- [9] Amoroso, R.L. & Vigier, J-P (2013) Evidencing 'tight bound states' in the hydrogen atom: Empirical manipulation of large-scale XD in violation of QED, in RL Amoroso, LH Kauffman & P. Rowlands (eds.), *The Physics of Reality: Space, Time, Matter, Cosmos*, Singapore: World Scientific Publishers.
- [10] Amoroso, R.L. (2013) Empirical protocol for mediating long-range coherence in biological systems, in press.
- [11] Amoroso, R.L. (2010) (ed.) *The Complementarity of Mind and Body: Realizing the Dream of Descartes, Einstein and Eccles*, New York: Nova Science Publishers.
- [12] Amoroso, R. L. (2013) *Crossing the Psycho-Physical Bridge: Elucidating the objective character of experience*, submitted.
- [13] Amoroso, R. L. (2012) Physical Parameters of Mind-Body Interaction: Breaking the 1st Person 3rd Person Barrier, *Journal of Nonlocality*, 1(1).
- [14] Gerlach, W. & Stern, O. (1922). *Das magnetische Moment des Silberatoms. Zeitschrift für Physik*, 9: 353–355.
- [15] Amoroso, R. L. (2013) A Simple Method for Surmounting Quantum Uncertainty, in Press.
- [16] Osoroma, D.S. (2013) Programmable Cellular Automata Properties of Covariant Dirac Polarized Spacetime, in RL Amoroso, LH Kauffman & P. Rowlands (eds.), *The Physics of Reality: Space, Time, Matter, Cosmos*, Singapore: World Scientific Publishers.
- [17] A. Dragic', Z. Maric', J.P. Vigier (2000) New quantum mechanical tight bound states and 'cold fusion' experiments, *Physics Letters A*: 265;163–167.
- [18] Nishino, H. et al. (2009) Super-K Collaboration Search for proton decay via $p^+ \rightarrow e^+ \pi^0$ & $p^+ \rightarrow \mu^+ \pi^0$ in a Large Water Cherenkov Detector, *Phys Rev Lett* 102: 14; 141801.
- [19] Sreekantan, B. V. (1984) Searches for proton decay and superheavy magnetic monopoles, *Journal of Astrophysics and Astronomy* 5 (3): 251–271.
- [20] Bohm, D. & Vigier, J-P (1954) Model of the causal interpretation of quantum theory in terms of a fluid with irregular fluctuations, *Phys. Rev.* 96:1; 208-217.
- [21] Holland, P.R. (1995) *The Quantum Theory of Motion: An Account of the de Broglie-Bohm Causal Interpretation of Quantum Mechanics*, Cambridge: Cambridge Univ. Press.
- [22] Cramer, J. (1986) The transactional interpretation of quantum mechanics, *Rev Mod Phys* 58, 647-687.
- [23] Wheeler, J.A. & Feynman, R. (1945) Interaction with the absorber as the mechanism of radiation, *Rev. Mod. Phys.* 17, 1578.
- [24] Feynman, Richard (1985) *QED: The Strange Theory of Light and Matter*, Princeton: Princeton Univ. Press.
- [25] Lehnert, B. (1994) Basic concepts of an extended electromagnetic field theory, *Speculations in Science and Technology-Complete Edition*, 17(4), 259-266.
- [26] Lehnert, B. (2006) An Extended Electromagnetic Theory, *Physica Scripta*, 1999 (T82), 89.
- [27] Lehnert, B., & Scheffel, J. (2006). On the minimum elementary charge of an extended electromagnetic theory. *Physica Scripta*, 65(3), 200.
- [28] Hainzl, C., Lewin, M., & Séré, É. (2005). Existence of a stable polarized vacuum in the Bogoliubov-Dirac-Fock approximation. *Comm. in Math. Physics*, 257(3), 515-562.
- [29] Cardone, F., & Mignani, R. (1999). Energy-dependent metric for gravitation from clock-rate experiments. *International Journal of Modern Physics A*, 14(24), 3799-3811.
- [30] Cardone, F., Francaviglia, M., & Mignani, R. (1999). Energy-Dependent Phenomenological Metrics & Five-Dimensional Einstein Equations. *Foundations of Physics Letters*, 12(3), 281-289.
- [31] Misner, Thorne, K. & Wheeler, J.A. (1990) *Gravitation*, San Francisco: AOS Press.
- [32] Witten, E. (1996) Reflections on the fate of spacetime, *Physics Today* (April), pp. 24-30.
- [33] Born, Max; Oppenheimer, J. Robert (1927). *Zur Quantentheorie der Molekeln* (On the Quantum Theory of Molecules) *Annalen der Physik* 389 (20): 457–484.
- [34] Kowalski, M. (2003). The Process of Photon Emission from Atomic Hydrogen. *Gravitation and Cosmology*: in RL Amoroso (eds) *the Hubble Radius to the Planck Scale*, 207-222.
- [35] Kowalski, M. (1999). Classical description of photon emission from atomic hydrogen. *Physics Essays*, 12(2), 312-331.
- [36] Kauffman, L. H., Rauscher, E. A., Rowlands, P., & Vigier, J. P. (2010). "Hidden" parameters describing internal motion within extended particle elements, in R.L. Amoroso, P. Rowlands & S. Jeffers (eds.) *Search for Fundamental Theory: The VII International Symposium Honoring French Mathematical Physicist Jean-Pierre Vigier*, AIP Conf. Proc., Vol. 1316, pp. 1-20.
- [37] Amoroso, R. L., & Rauscher, E. A. (2010, December). Empirical Protocol for Measuring Virtual Tachyon/Tardon Interactions in a Dirac Vacuum. In *AIP Conference Proceedings* (Vol. 1316, p. 199-222).
- [38] Luminet, J-P (2003) Dodecahedral space topology as an explanation for weak wide-angle temperature correlations in the cosmic microwave background, arXiv:astro-ph/0310253v1.